

BNC Series

Strongest Clamping Torque

The clamping Torque is 3,000Nm with built-in Air Hydraulic unit.

Big Bore

The biggest table center hole diameter of 160 mm in the class. It is available for big diameter and long work pieces

Accurate indexing

Accurate indexing is available by durable worm wheel of special alloy. Indexing accuracy within 20 seconds cumulatively.



- Rigid bearing structure
 - Easy maintenance
 - Outstanding water protection
- Unit: mm

Model	BNC320R	
Table diameter	320	
Center height	230	
Table faucet hole diameter	170H7	
Table center through hole dia.	160	
Clamp system	Air pressure (0.3~0.5MPa)	
Clamp torque	(N·m)	3,000(0.5MPa)
Indexing accuracy (cumulative)	(sec.)	20
Allowable operation load (N)	Vertical load	18,000
	Horizontal load	11,000
	Circumferential load	18,000
Allowable inertia Moment (kg·m ²)	During vertical use	5.00
	During horizontal use	2.50
Total reduction ratio	1/90	
Maximum rotation	(min ⁻¹)	22.2
Guide piece width	18h7	
Product weight	(kg)	174

Outside dimensions [PDF](#)

- * Guide piece (2pcs), Fixtures (2sets), Air tube (5m) for table clamping are attached.
- * Corresponding to Controller for CNC rotary table or to motor for additional axis.

BNC320R-AC3-90

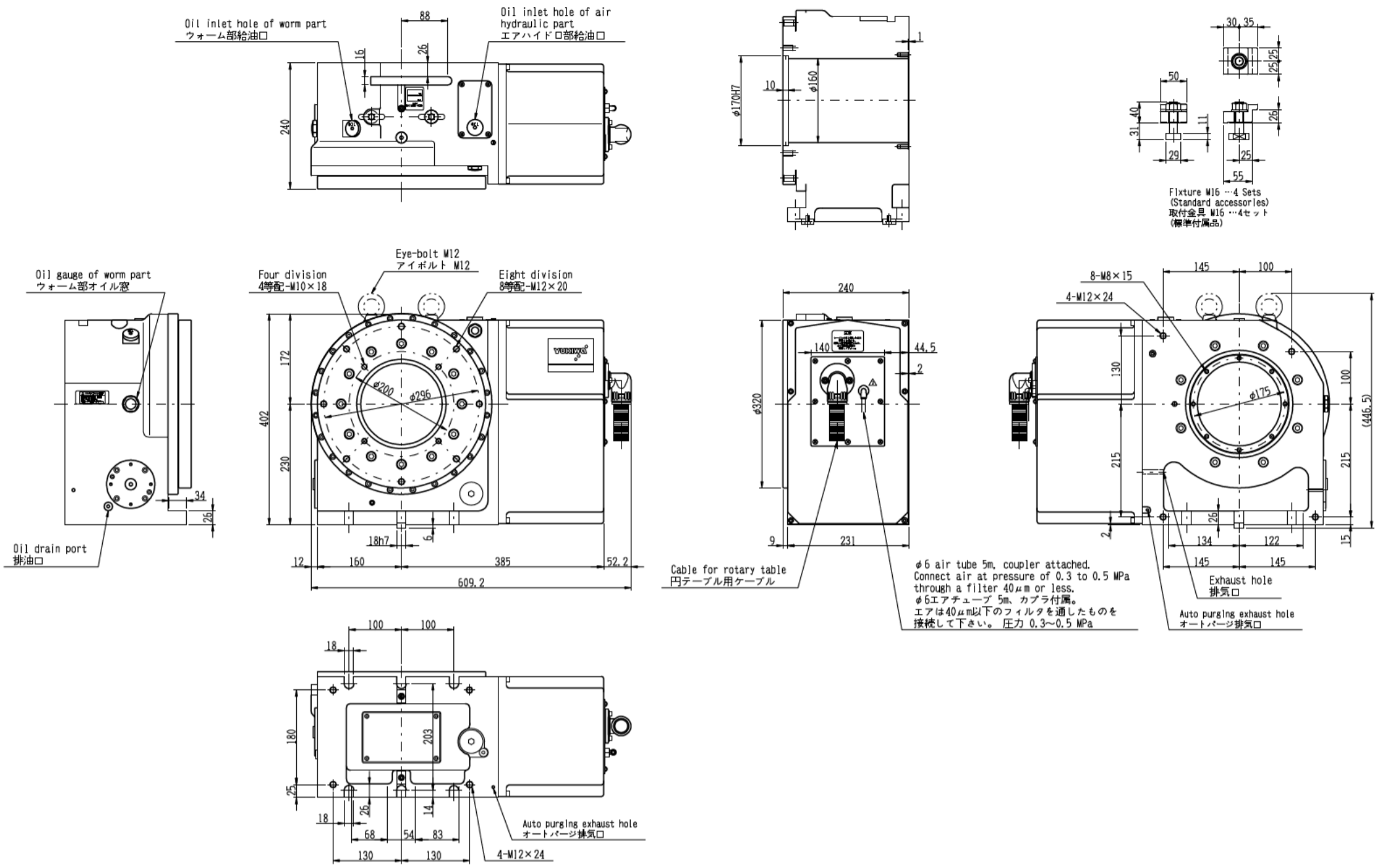

BNC320R-AX (FANUC α iF8)

